

EXTRUSION

VALCO

PARTITIONS

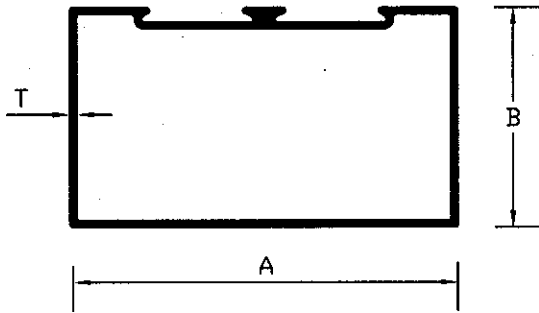

SEC	A	B	T	Wt/m	Wt/15'
11001	63.50	38.00	1.20	0.66	3.01
11002	63.50	38.00	1.40	0.77	3.51
11003	63.50	38.00	1.60	0.88	4.01
11006	63.50	38.00	2.00	1.10	5.02
11008	63.50	38.00	3.00	1.64	7.53
11012	101.60	44.45	1.45	1.10	5.10
11013	101.60	44.45	1.60	1.26	5.78
11015	101.60	44.45	1.70	1.35	6.20
11016	101.60	44.45	2.00	1.63	7.45
11017	101.60	44.45	2.50	2.02	9.25
11018	101.60	44.45	3.00	2.42	11.06
11019	101.60	44.45	3.15	2.53	11.60
11020	101.60	44.45	3.50	2.81	12.86
19003	83.50	38.00	1.60	1.05	4.81
19006	83.50	38.00	2.00	1.31	6.01
19007	83.50	38.00	2.50	1.64	7.51
19008	83.50	38.00	3.00	1.97	9.01
19013	50.80	25.40	1.20	0.49	2.26
19014	50.80	25.40	1.60	0.66	3.01

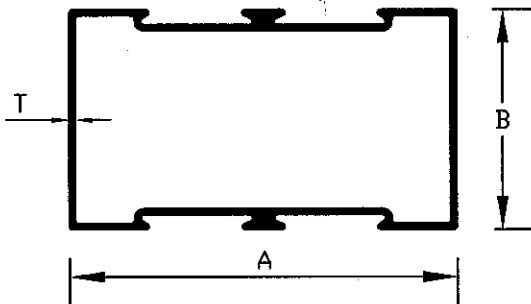

SEC	A	B	T	Wt/m	Wt/15'
11021	63.50	38.00	1.20	0.66	3.01
11022	63.50	38.00	1.40	0.77	3.51
11023	63.50	38.00	1.60	0.88	4.01
11026	63.50	38.00	2.00	1.10	5.02
11028	63.50	38.00	3.00	1.64	7.53
11032	101.60	44.45	1.45	1.11	5.10
11033	101.60	44.45	1.60	1.26	5.78
11035	101.60	44.45	1.70	1.35	6.20
11036	101.60	44.45	2.00	1.66	7.59
11037	101.60	44.45	2.50	2.09	9.57
11038	101.60	44.45	3.00	2.45	11.20
11039	101.60	44.45	3.15	2.56	11.74
11040	101.60	44.45	3.50	2.84	13.00
19023	83.50	38.00	1.60	1.13	5.17
19026	83.50	38.00	2.00	1.39	6.37
19027	83.50	38.00	2.50	1.72	7.87
19028	83.50	38.00	3.00	2.05	9.38
19033	50.80	25.40	1.20	0.49	2.26
19034	50.80	25.40	1.60	0.66	3.01
19048	150.80	44.45	3.00	3.21	14.70

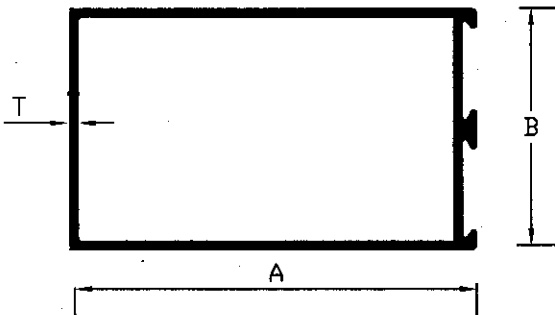

SEC	A	B	T	Wt/m	Wt/15'
11041	47.50	44.45	1.20	0.61	2.80
11042	47.50	44.45	1.40	0.70	3.18
11043	47.50	44.45	1.60	0.79	3.64
11045	47.50	44.45	1.80	0.89	4.09
11046	47.50	44.45	2.00	0.99	4.55
11048	47.50	44.45	3.00	1.54	7.05
11052	83.50	44.45	1.40	1.10	5.00
11053	83.50	44.45	1.60	1.16	5.29
11056	83.50	44.45	2.00	1.43	6.55
11057	83.50	44.45	2.55	1.83	8.30
11058	83.50	44.45	3.00	2.15	9.83

EXTRUSION

VALCO

DOORS

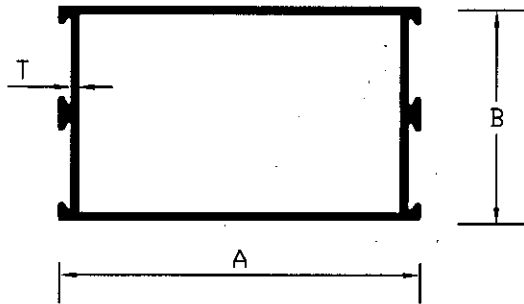

SEC	A	B	T	Wt/m	Wt/15'
11061	47.50	44.45	1.26	0.61	2.80
11062	47.50	44.45	1.40	0.70	3.28
11063	47.50	44.45	1.60	0.79	3.64
11065	47.50	44.45	1.80	0.89	4.09
11066	47.50	44.45	2.00	0.99	4.55
11068	47.50	44.45	3.00	1.53	7.00
11072	83.50	38.00	1.40	1.04	4.80
11073	83.50	44.45	1.61	1.19	5.46
11076	83.50	44.45	2.00	1.40	6.40
11077	85.00	44.45	2.55	1.86	8.53
11078	85.00	44.45	3.00	2.18	9.97
19076	150.00	44.45	2.00	2.18	9.98
19078	150.00	38.00	3.00	3.23	14.79

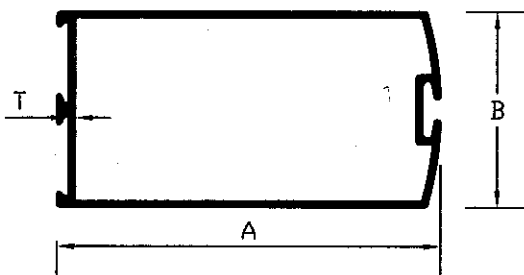

SEC	A	B	T	Wt/m	Wt/15'
11101	47.50	44.45	1.20	0.60	2.80
11102	47.50	44.45	1.40	0.70	3.28
11103	47.50	44.45	1.60	0.79	3.64
11105	47.50	44.45	1.80	0.89	4.09
11106	47.50	44.45	2.00	0.99	4.55
11108	47.50	44.45	3.00	1.51	6.91
11112	83.50	44.45	1.40	1.10	5.00
11113	83.50	44.45	1.60	1.16	5.29
11116	83.50	44.45	2.00	1.43	6.55
11117	85.00	44.45	2.55	1.83	8.39
11118	85.00	44.45	3.00	2.15	9.83

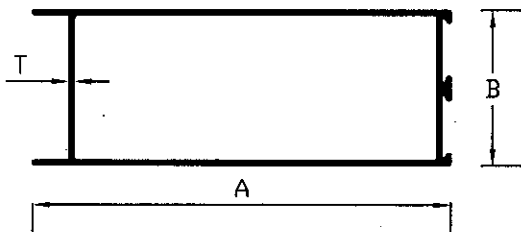

SEC	A	B	T	Wt/m	Wt/15'
11081	47.50	44.45	1.20	0.61	2.80
11082	47.50	44.45	1.40	0.70	3.28
11083	47.50	44.45	1.60	0.79	3.64
11085	47.50	44.45	1.80	0.89	4.09
11086	47.50	44.45	2.00	0.99	4.55
11088	47.50	44.45	3.00	1.49	6.82
11182	83.50	44.45	1.40	1.11	4.80
11183	83.50	44.45	1.60	1.18	5.40
11186	83.50	44.45	2.00	1.38	6.33
11188	83.50	44.45	3.00	2.07	9.49
11192	101.00	44.45	1.40	1.10	5.03
11193	101.00	44.45	1.60	1.26	5.75
11092	114.50	44.45	1.30	1.20	5.49
11093	114.50	44.45	1.60	1.38	6.30
11096	114.50	44.45	2.00	1.77	8.09
11097	114.50	44.45	2.55	2.24	10.25
11098	114.50	44.45	3.00	2.62	12.02
19096	150.00	44.45	2.00	2.15	9.95
19098	150.00	44.45	3.00	3.20	14.65

EXTRUSION

VALCO

GLAZING CLIP & PLATE

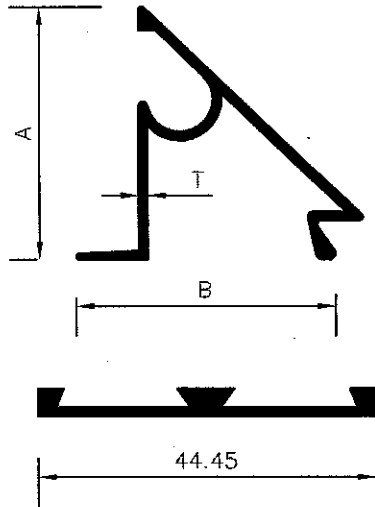

SEC	A	B	T	Wt/m	Wt/15'
11141	16.85	16.75	0.55	0.06	0.26
11142	16.85	16.75	0.65	0.07	0.27
11143	16.85	16.75	0.80	0.08	0.29
11144	16.85	16.75	0.85	0.09	0.31
11145	16.85	16.75	0.90	0.10	0.36
11146	16.85	16.75	1.00	0.11	0.40
11148	16.85	16.75	1.10	0.12	0.44
11148	16.85	16.75	1.25	0.14	0.51
11149	16.85	16.75	1.60	0.18	0.66
SEC	A	B	Wt/m	Wt/15'	
11121	44.45	0.65	0.14	0.51	
11122	44.45	0.75	0.15	0.55	
11123	44.45	0.80	0.17	0.62	
11124	44.45	0.85	0.18	0.65	
11125	44.45	1.00	0.21	0.77	
11126	44.45	1.60	0.33	1.20	

RECTANGULAR TUBE

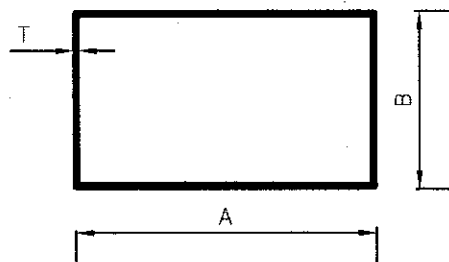

SEC	A	B	T	Wt/m	Wt/12'
11131	38.00	25.00	1.20	0.41	1.50
11179	40.00	20.00	1.30	0.42	1.10
11171	40.00	25.00	1.20	0.41	1.50
11132	50.80	25.00	1.20	0.49	1.80
11133	50.80	25.00	1.60	0.65	2.40
11134	50.80	25.00	2.00	0.82	3.00
11176	63.50	12.00	1.15	0.51	1.89
11175	63.50	38.00	5.00	2.61	9.55
11135	63.50	38.10	1.00	0.55	2.01
11136	63.50	38.10	1.40	0.77	2.82
11137	63.50	38.10	1.60	0.88	3.22
11138	63.50	38.10	2.00	1.10	4.02
11139	63.50	38.10	2.50	1.37	5.03
11140	63.50	38.10	3.00	1.65	6.03
11180	68.40	23.40	1.20	0.59	2.17
11174	70.00	20.00	2.00	0.95	3.47
11173	74.00	21.00	3.00	1.47	5.40
11160	76.00	25.00	2.00	1.09	4.00
11161	79.20	50.00	2.00	1.40	5.10
11177	80.00	20.00	1.30	0.70	2.57
11194	80.00	30.00	2.00	1.14	4.20
11178	80.00	40.00	1.50	0.96	3.54
11163	100.00	25.00	1.60	1.08	3.96
11164	100.00	25.00	2.00	1.35	4.95
11165	101.60	44.45	2.00	1.58	5.78
11166	101.60	44.45	2.50	1.97	7.23
11167	101.60	44.45	3.00	2.37	8.67
11162	125.00	25.00	1.20	0.98	3.60
11169	127.00	38.00	3.00	2.67	9.80
11168	127.00	44.45	3.00	2.80	10.16
11170	150.00	50.00	3.00	3.16	14.46

EXTRUSION

VALCO

SQUARE TUBE

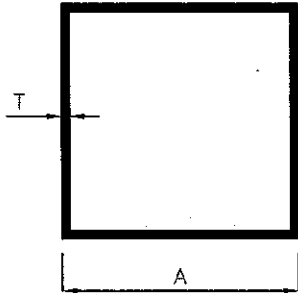

SEC	A	B	T	Wt/m	Wt/12'
12202	15.80	15.80	1.27	0.22	0.79
12203	16.00	16.00	0.50	0.09	0.32
12205	19.00	19.00	1.20	0.25	0.90
12206	19.00	19.00	1.60	0.33	1.20
12221	20.00	20.00	2.00	0.43	1.60
12208	23.50	23.50	0.50	0.13	0.47
12209	23.50	23.50	0.65	0.16	0.60
12210	23.50	23.50	0.90	0.23	0.84
12211	23.50	23.50	1.20	0.30	1.12
12207	23.50	23.50	2.00	0.51	1.86
12212	32.00	32.00	1.50	0.52	1.90
12213	32.00	32.00	3.00	1.02	3.75
12220	38.00	38.00	1.25	0.51	1.88
12222	38.00	38.00	2.00	0.82	3.00
12223	38.00	38.00	3.00	1.25	4.50
12215	50.80	50.00	1.40	0.76	2.77
12216	50.80	50.80	1.50	0.82	3.02
12217	50.80	50.80	3.15	1.73	6.34
12226	63.50	63.50	2.00	1.37	5.01
12227	63.50	63.50	3.00	2.00	7.32
12225	101.60	101.60	3.15	3.37	12.34

ARCHITECTURAL ACCESSORIES

12284 0.985Kg/m

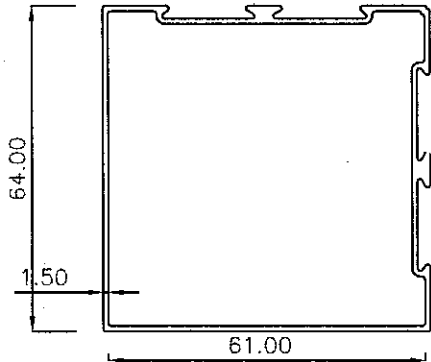

12278 0.978Kg/m

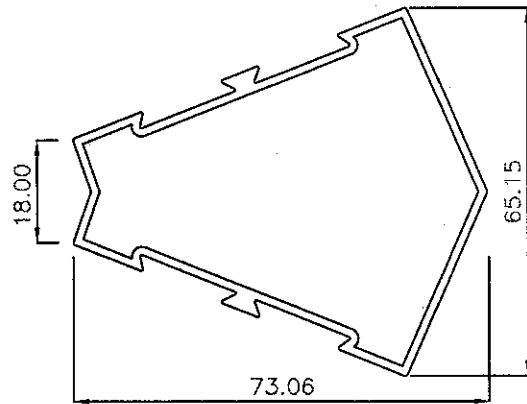

17254 0.435Kg/m

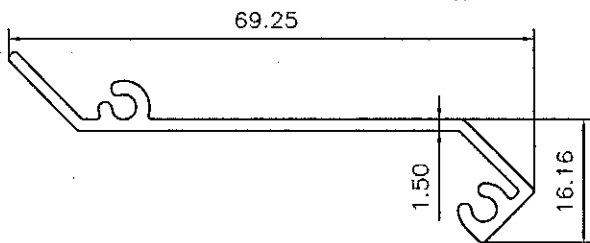

EXTRUSION

VALCO

ARCHITECTURAL ACCESSORIES

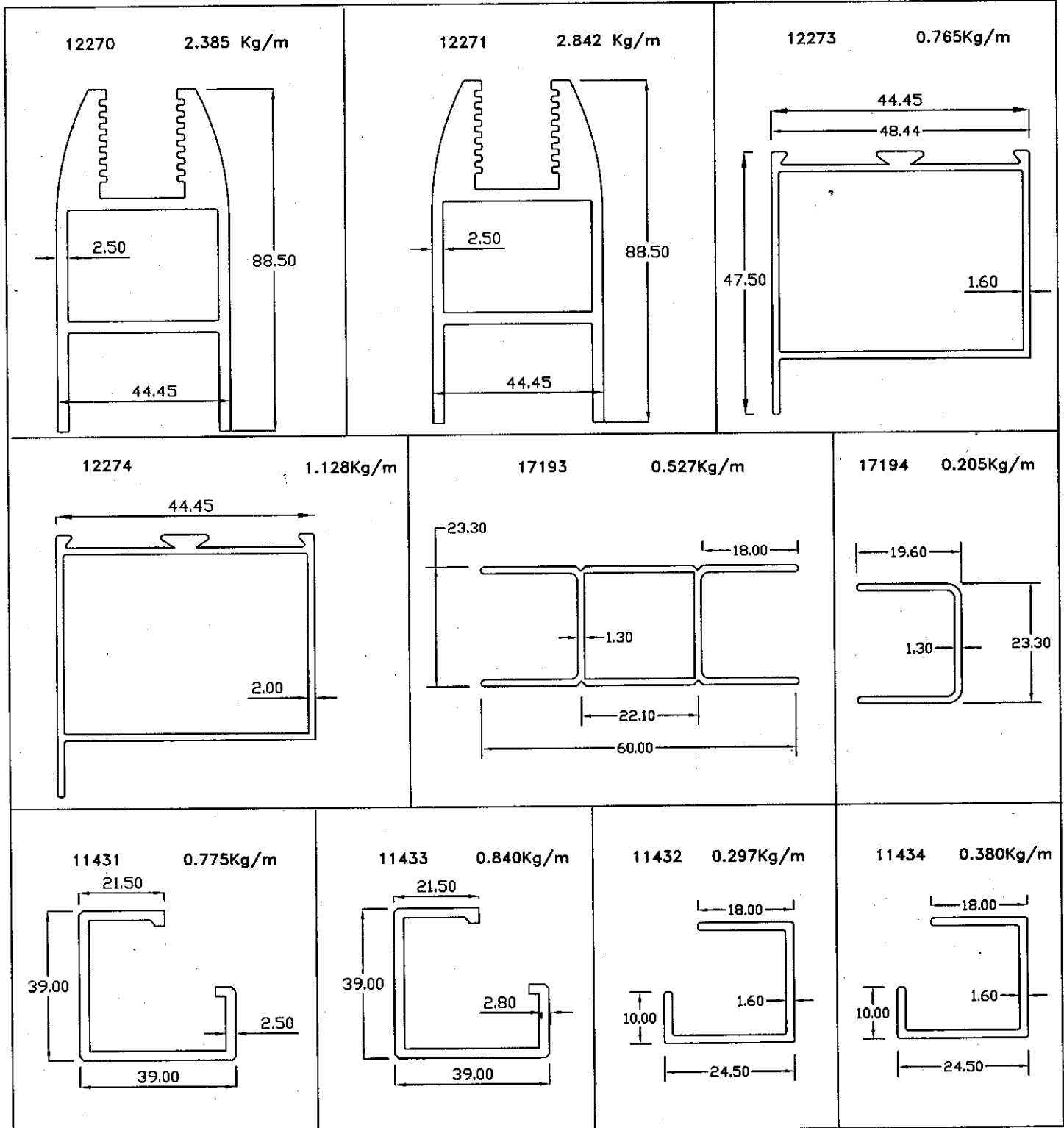

EXTRUSION

VALCO

SLIDING WINDOWS

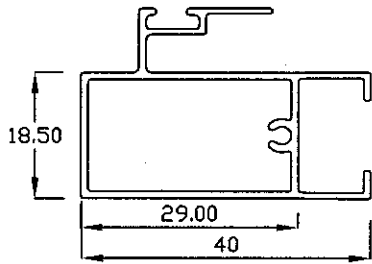

S.L. NO.	Section No.	T	Weight Kg/m
1	13201	1.00	0.421
2	13202	1.20	0.481
3	13203	1.60	0.615

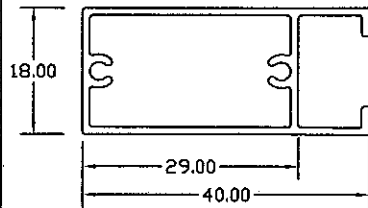

S.L. NO.	Section No.	T	Weight Kg/m
1	13206	1.00	0.345
2	13207	1.20	0.400
3	13208	1.60	0.550

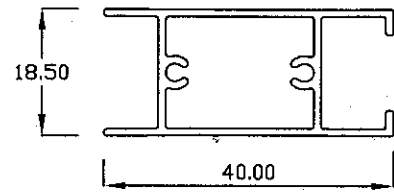

S.L. NO.	Section No.	T	Weight Kg/m
1	13215	1.00	0.345
2	13216	1.20	0.400
3	13217	1.60	0.550

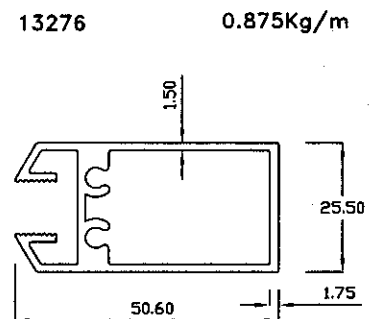
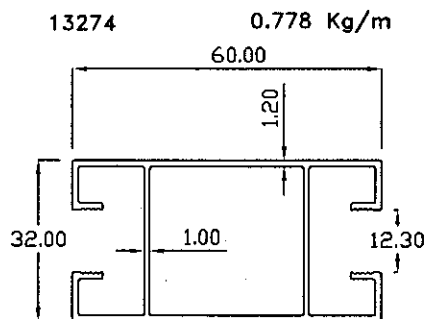
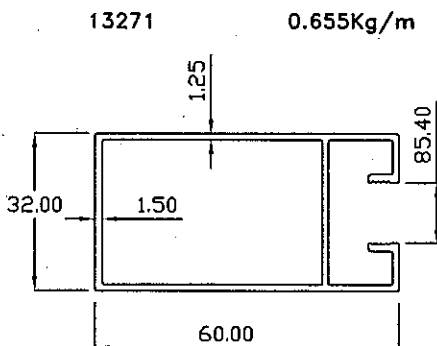
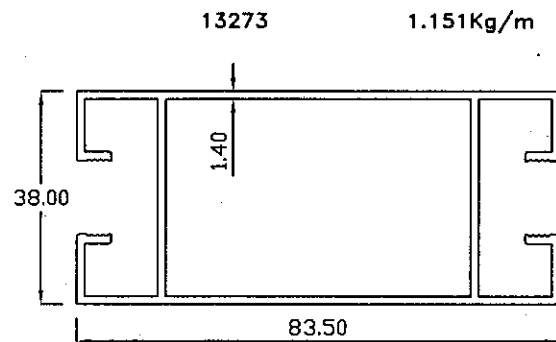
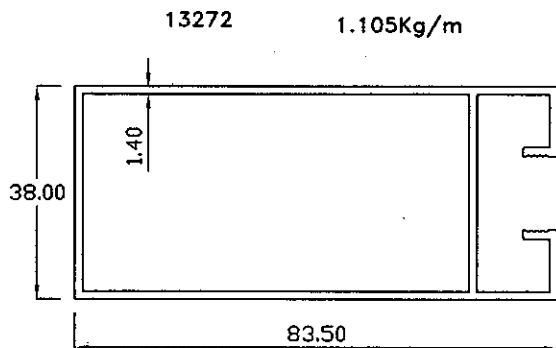

EXTRUSION

VALCO

SLIDING WINDOWS

13251

0.491Kg/m

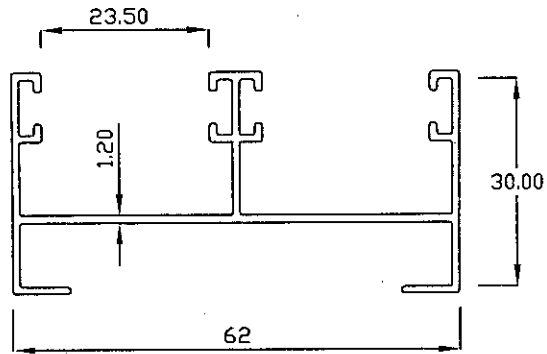

13256

0.561Kg/m

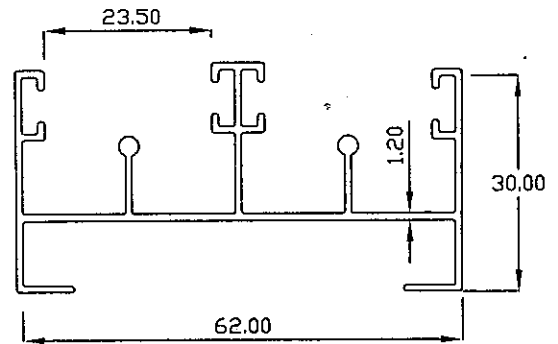

13266

0.945Kg/m

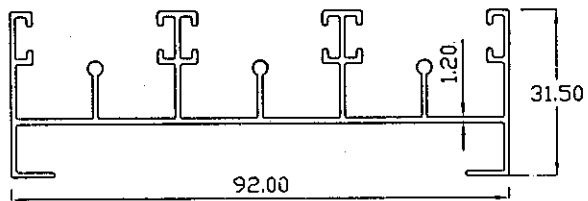

13266

0.951Kg/m

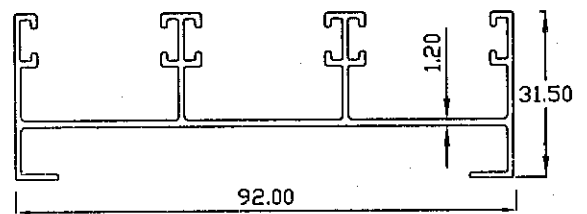

13267

1.152Kg/m

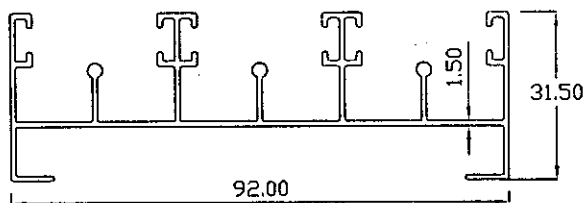

13267

1.252Kg/m

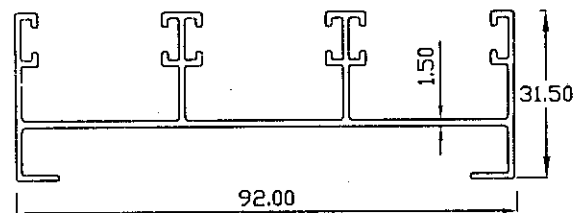

EXTRUSION

VALCO

CASEMENT WINDOWS

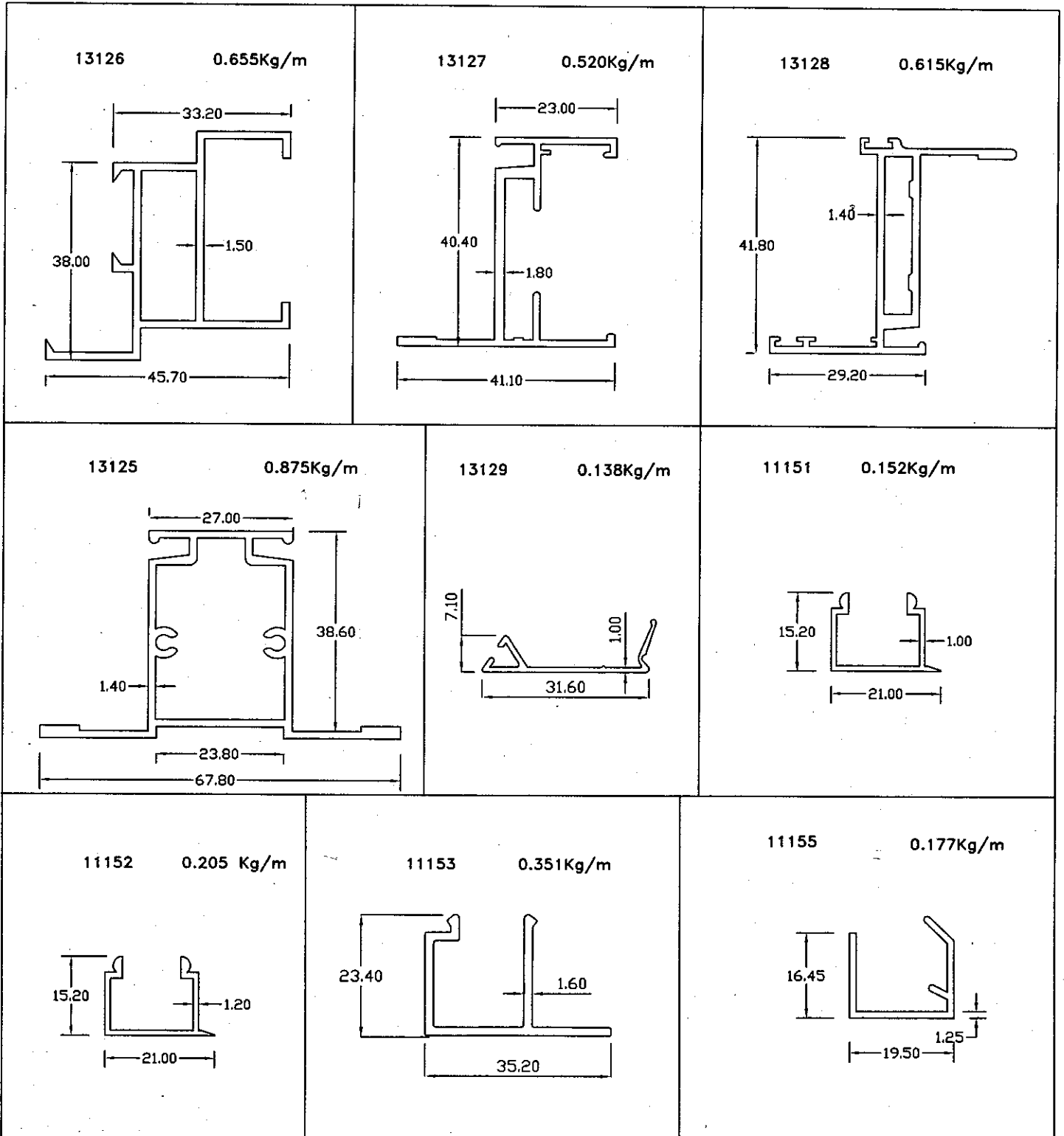

EXTRUSION

VALCO

CASEMENT WINDOWS

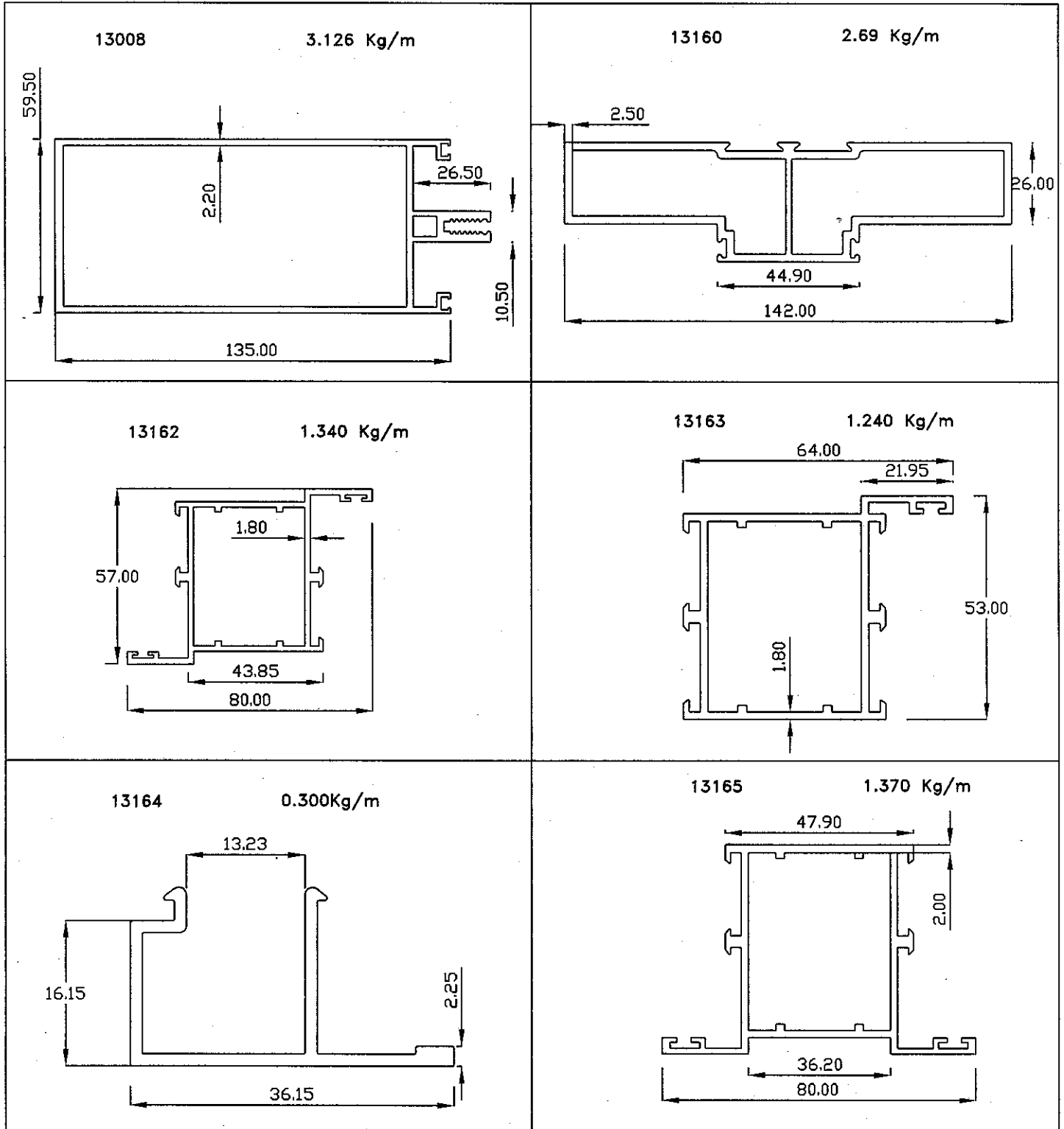

EXTRUSION

VALCO

CASEMENT WINDOWS

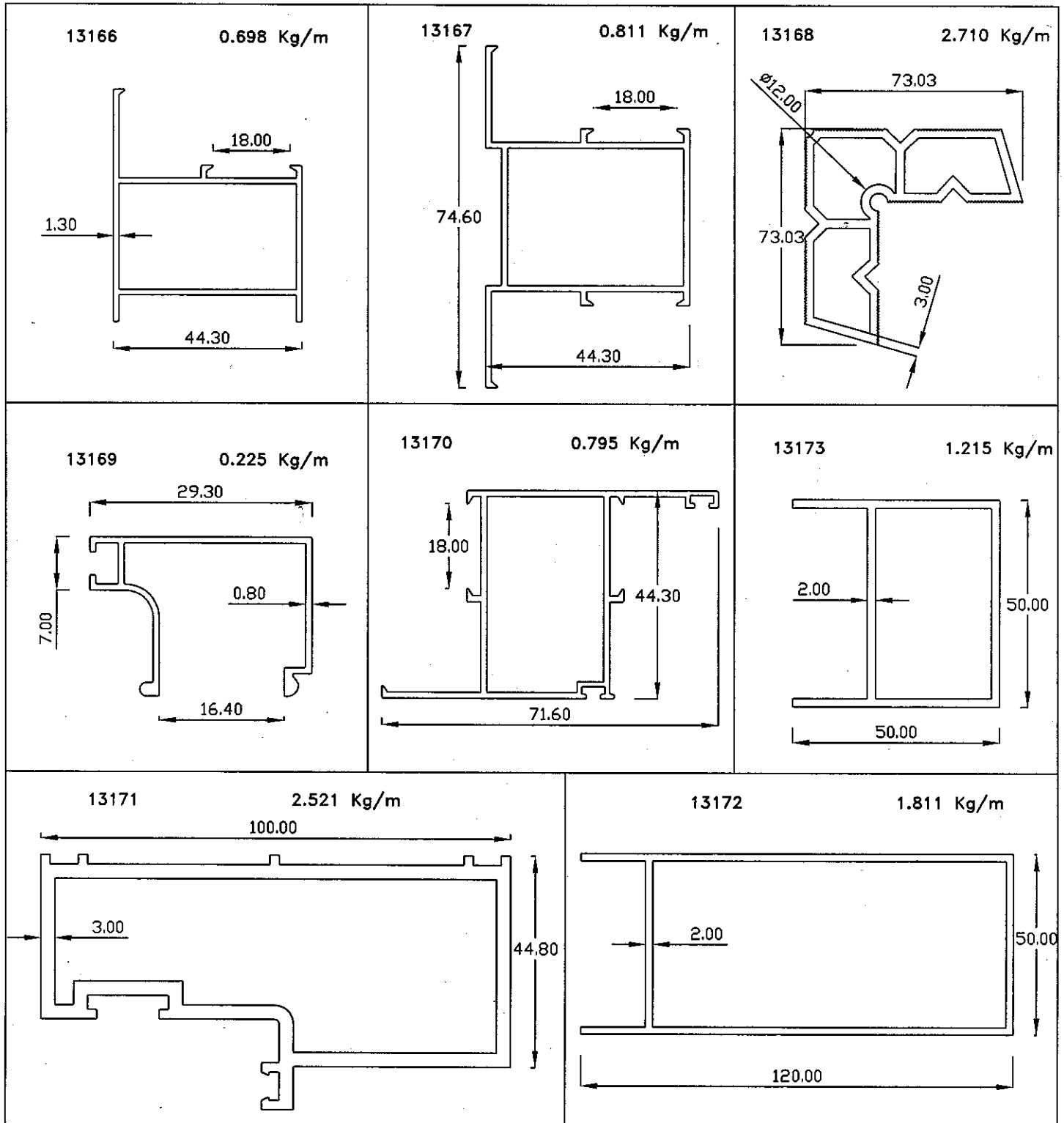

EXTRUSION

VALCO

CASEMENT WINDOWS

18090

0.315 Kg/mt

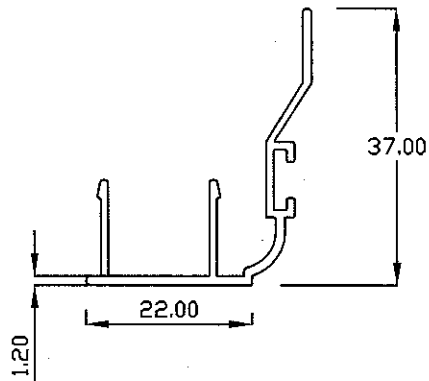

18091

0.860 Kg/mt

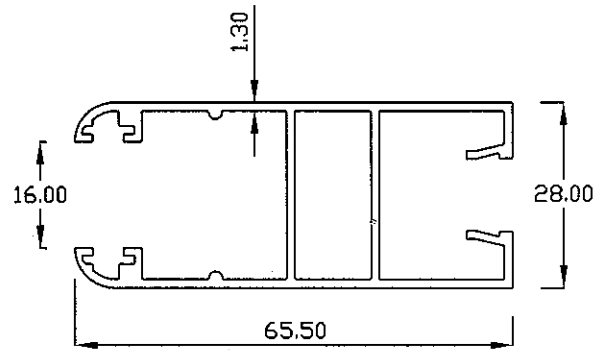

18092

1.030 Kg/mt

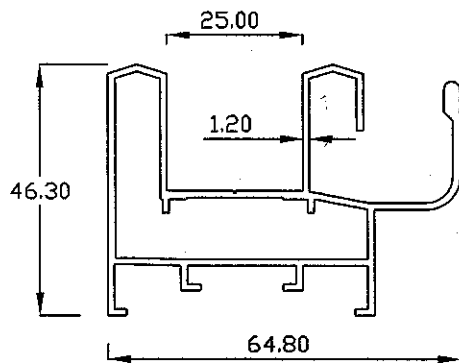

18181

0.316 Kg/m

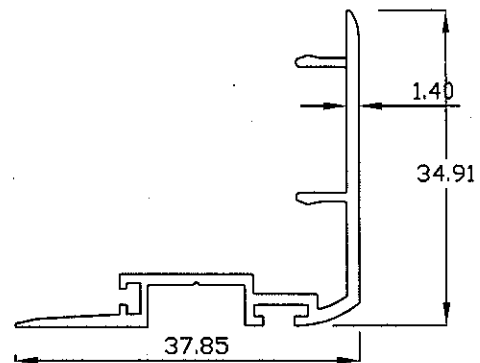

18182

0.923Kg/m

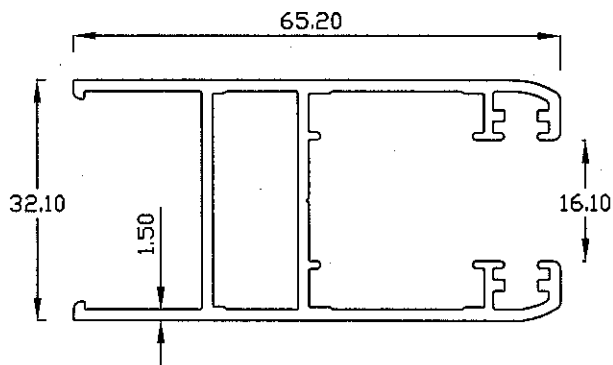

18183

0.606 Kg/mt

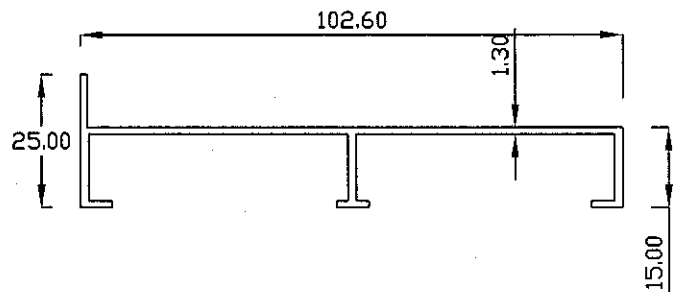

EXTRUSION

VALCO

CASEMENT WINDOWS

18184

2.124 Kg/mt

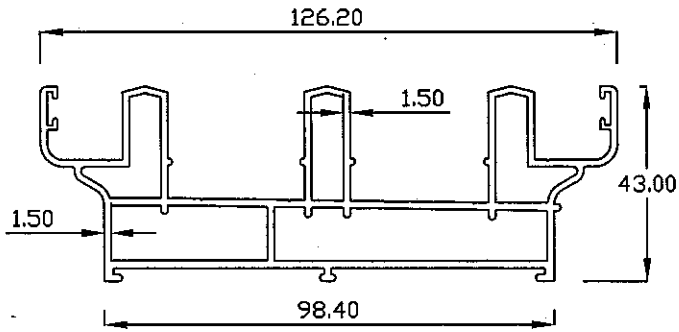

18185

0.235 Kg/mt

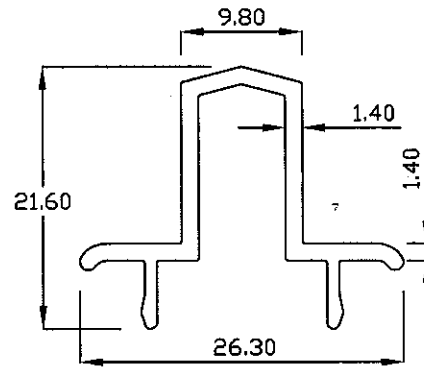

18186

0.272 Kg/mt

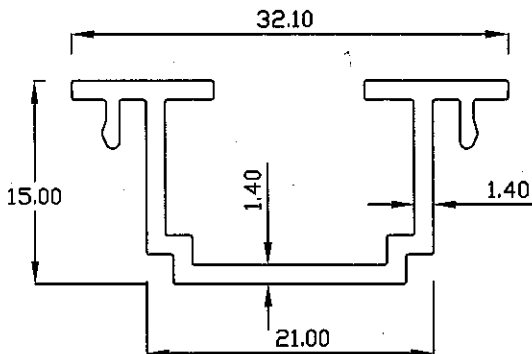

18187

1.791Kg/mt

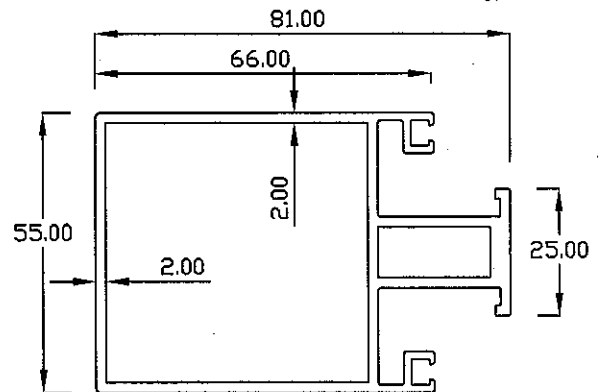

18188

1.520 Kg/mt

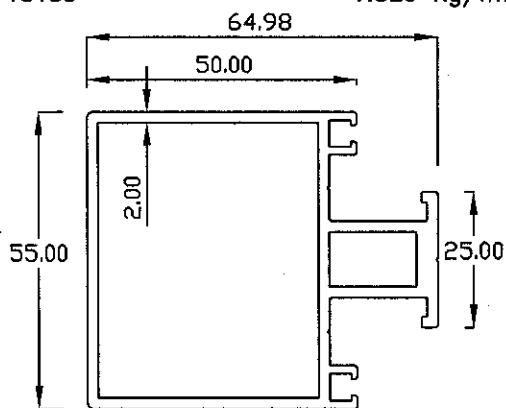

18189

2.590 Kg/m

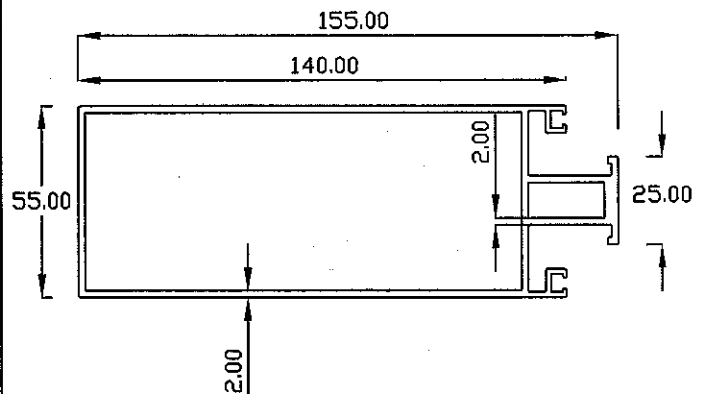

EXTRUSION CASEMENT WINDOWS

VALCO

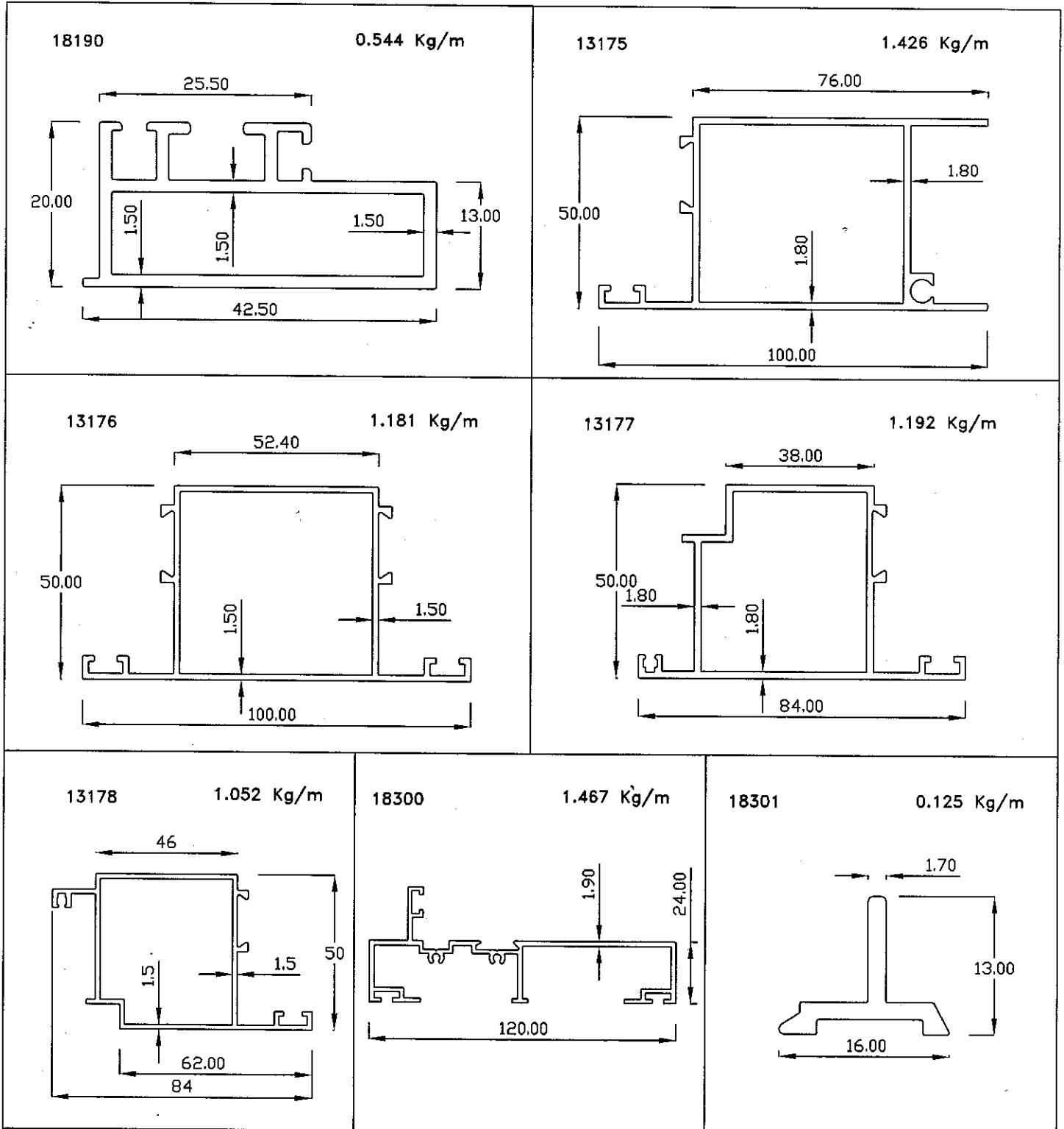

EXTRUSION

VALCO

CASEMENT WINDOWS

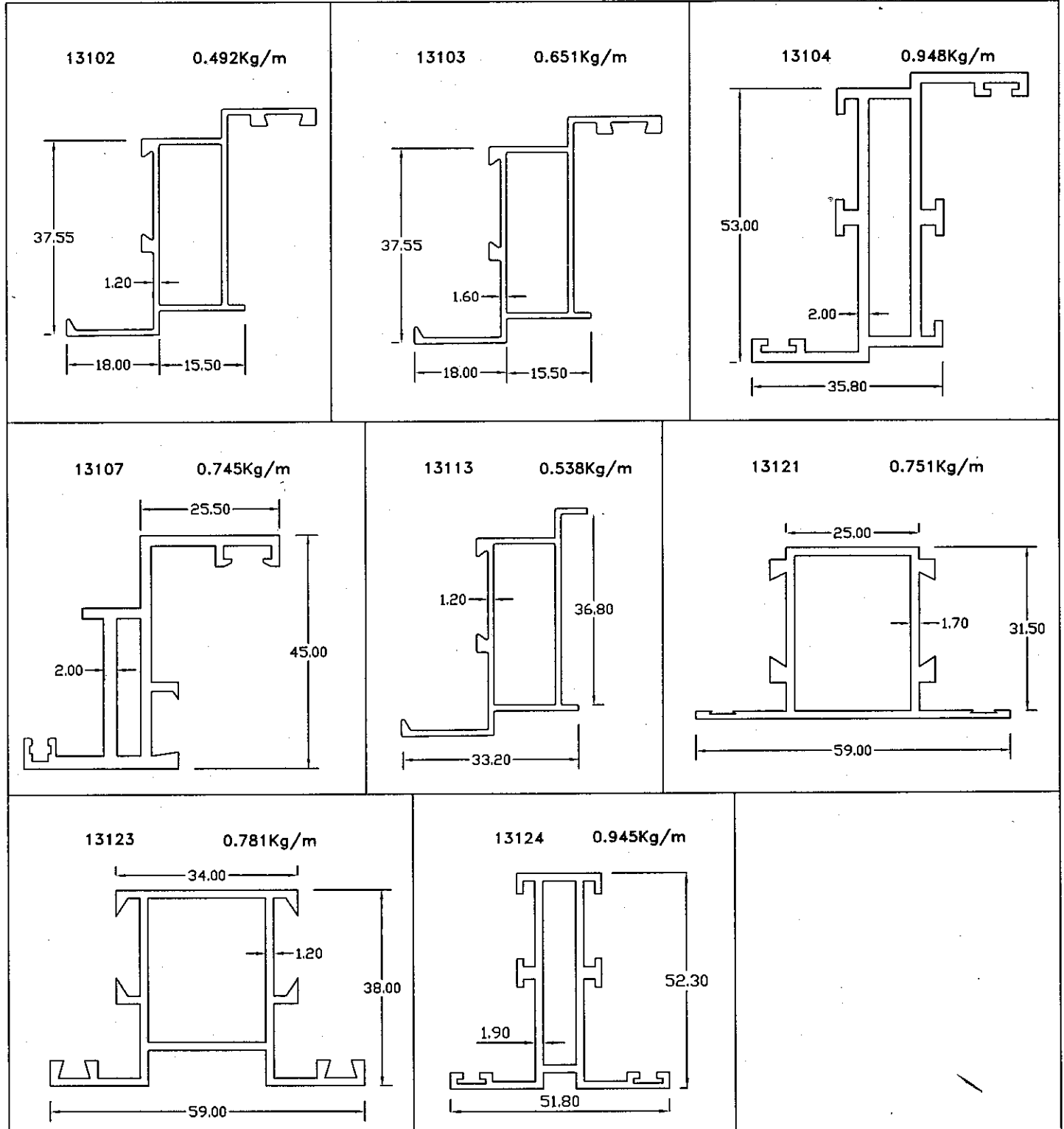

EXTRUSION

VALCO

CURTAIN WALLING

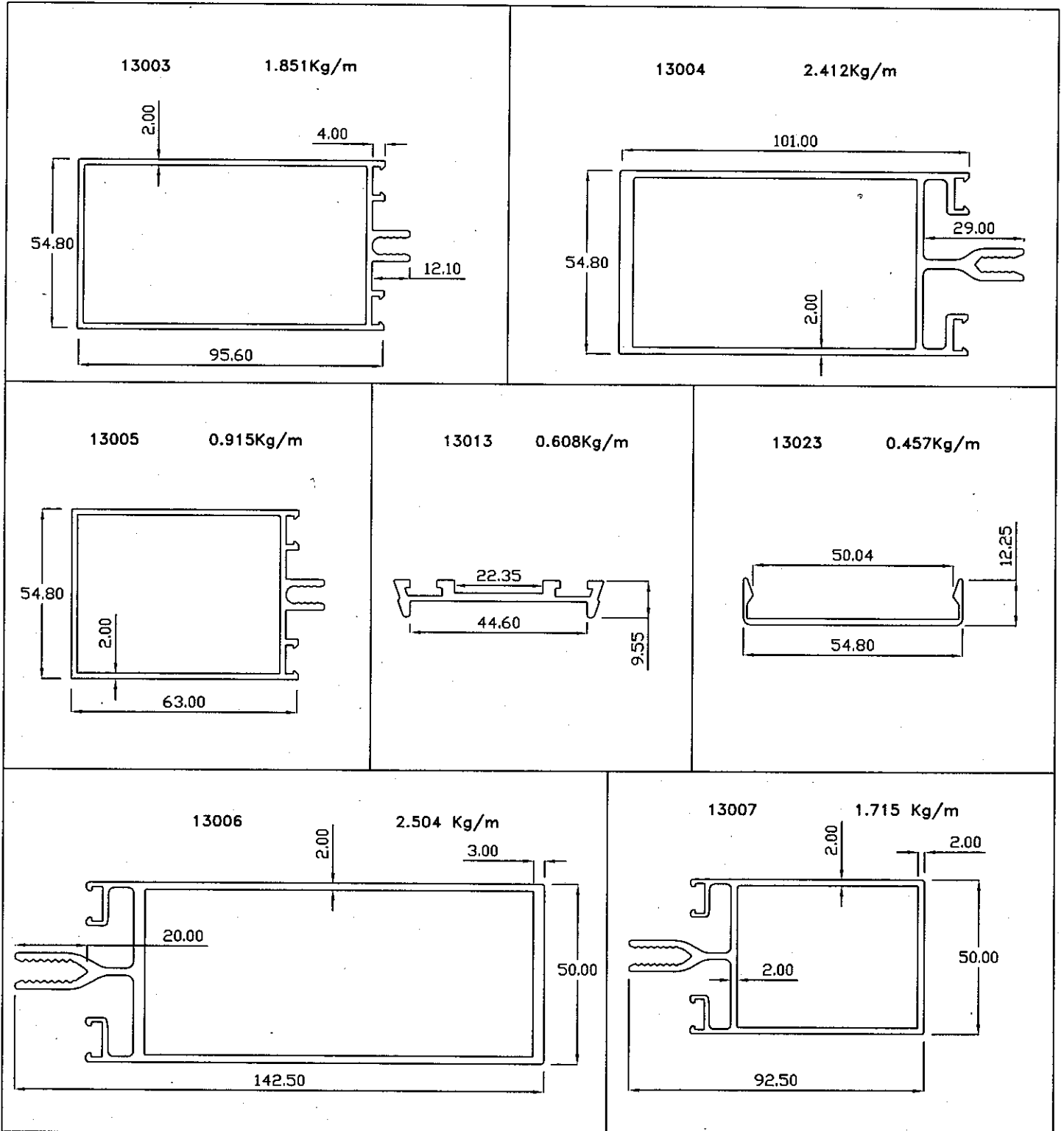

EXTRUSION

VALCO

CURTAIN WALLING

12277

0.834 Kg/m

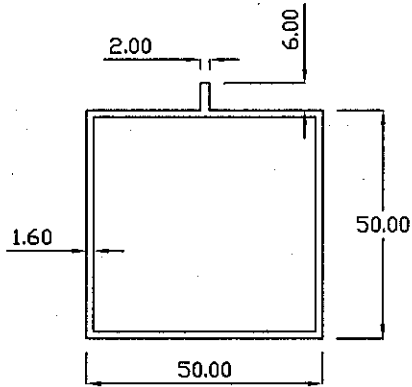

12279

1.351Kg/m

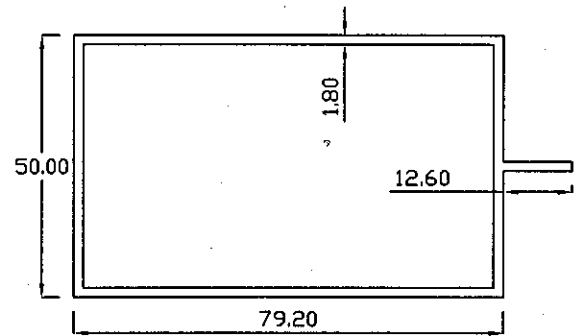

12281

0.929Kg/m

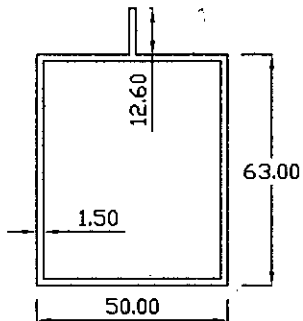

12282

1.215Kg/m

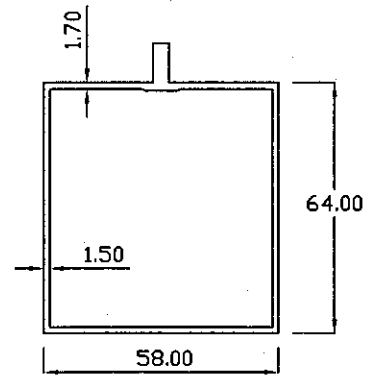

EXTRUSION

VALCO

PATTAM SECTIONS

13135

0.400Kg/m

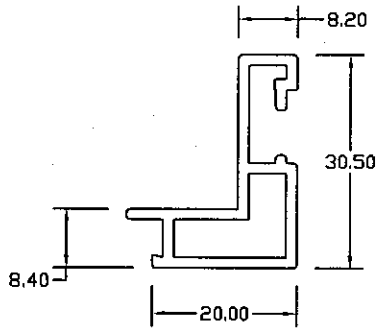

13136

1.56Kg/m

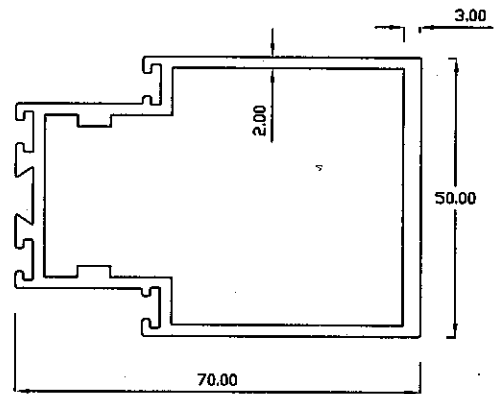

13137

2.68kg/m

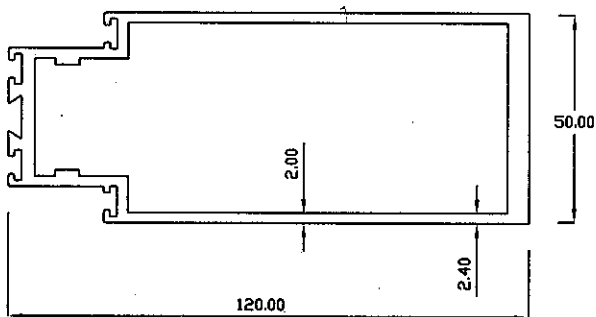

13138

2.95Kg/m

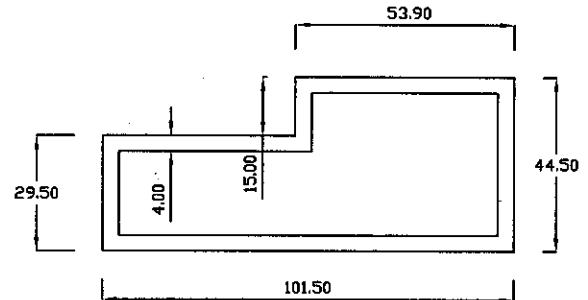

13141

0.890Kg/m

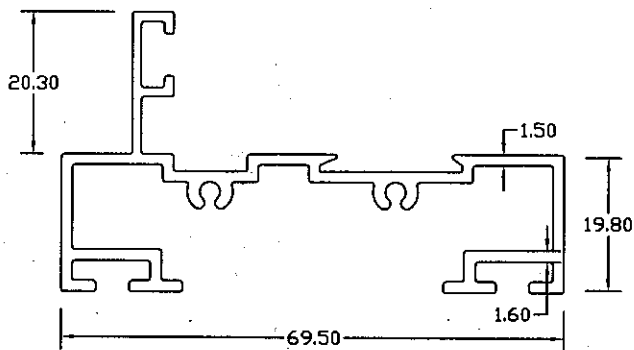

13142

0.240Kg/m

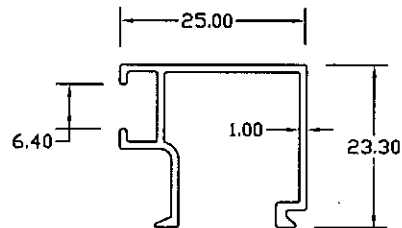

EXTRUSION

VALCO

PATTAM SECTIONS

13143

1.09Kg/m

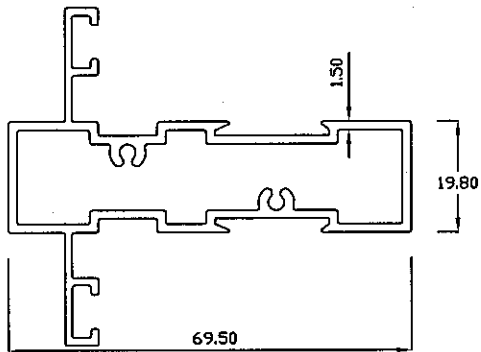

13144

0.850Kg/m

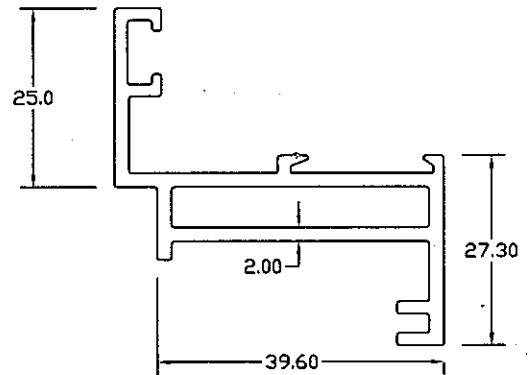

13157

0.125/Kg/m

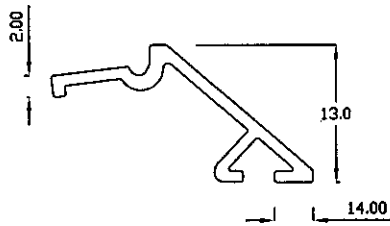

13151

1.41Kg/m

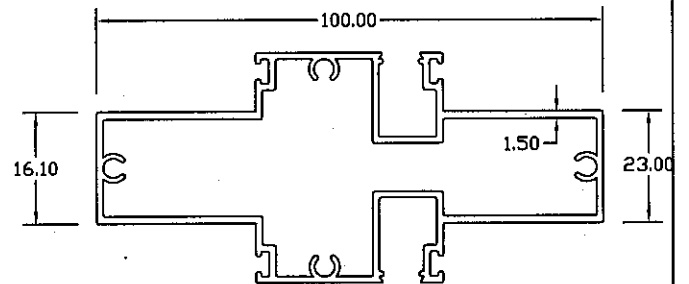

13152

1.08Kg/m

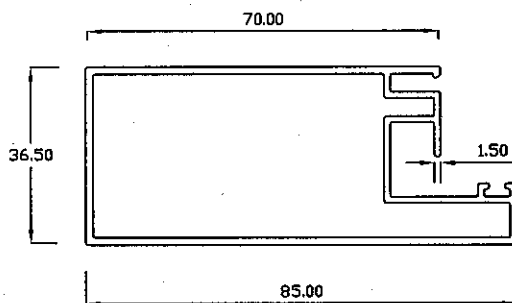

13153

0.888Kg/m

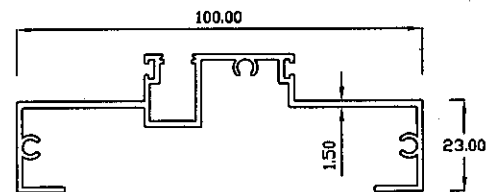

EXTRUSION

VALCO

PATTAM SECTIONS

13154

0.345Kg/m

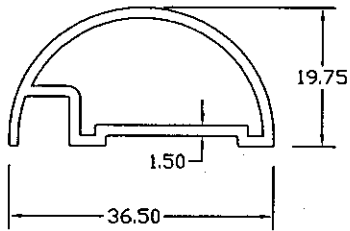

13155

0.114Kg/m

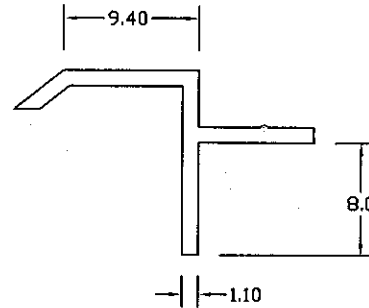

13156

0.782Kg/m

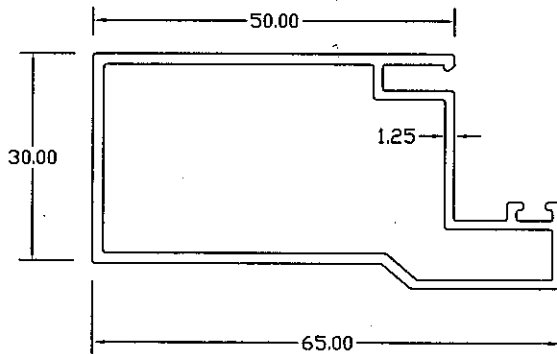

12272

0.868Kg/m

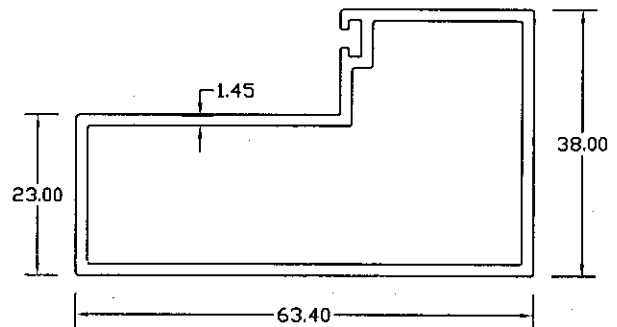

12285
11185

0.961Kg/m

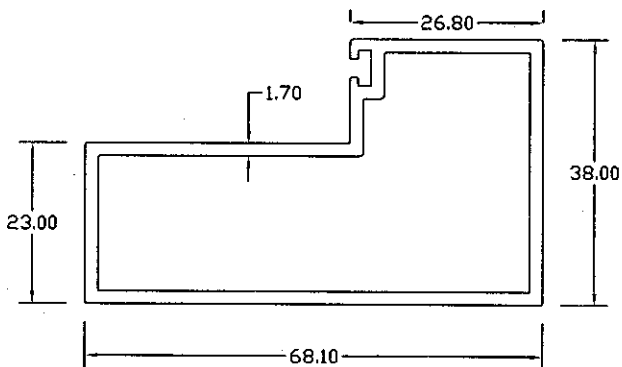

13174

2.032Kg/m

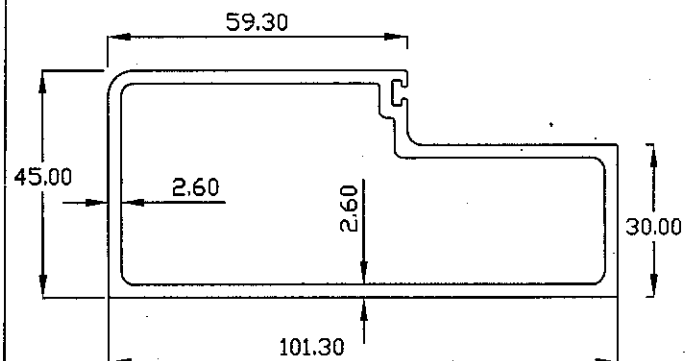

EXTRUSION

VALCO

PATTAM SECTIONS

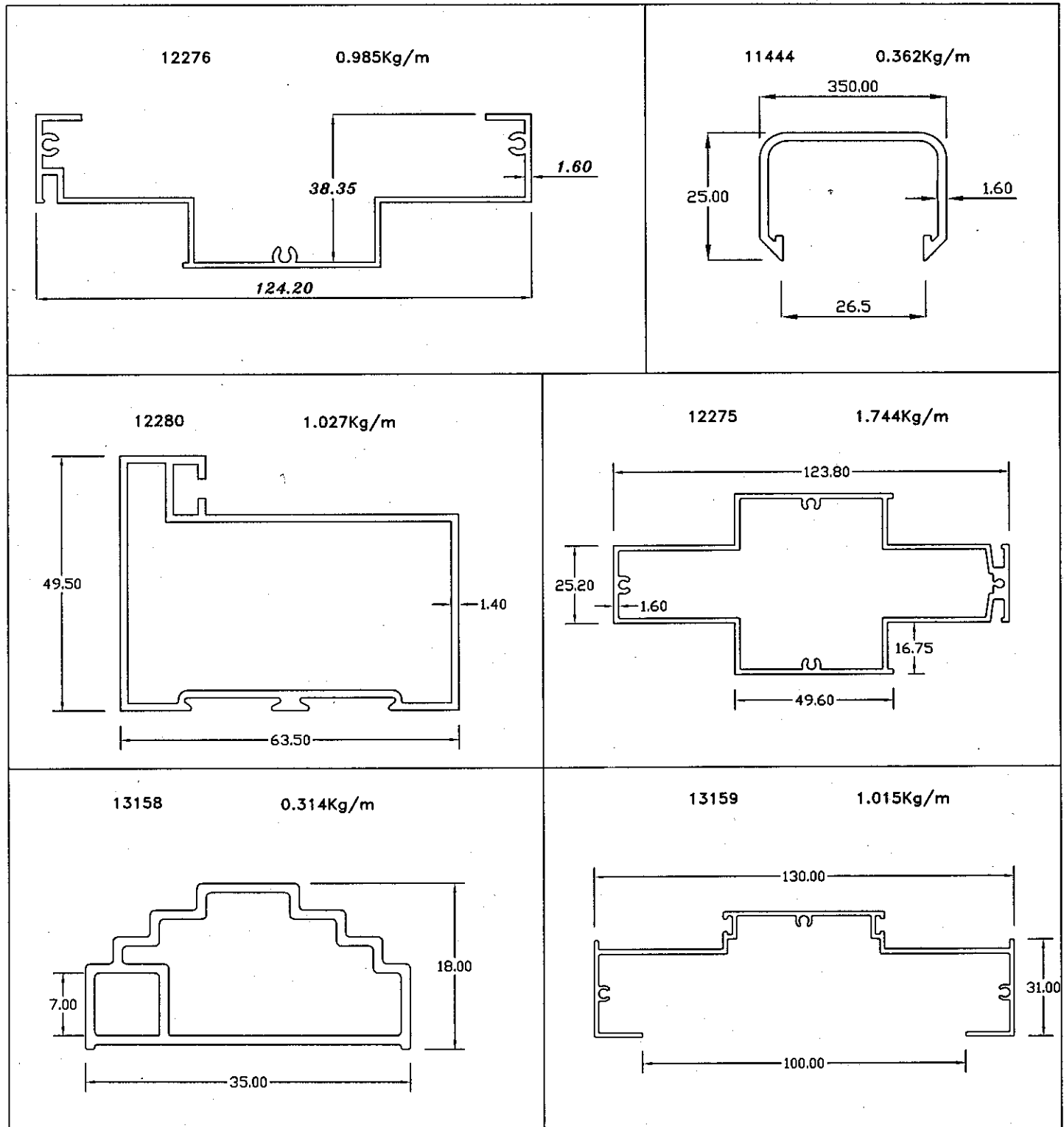

EXTRUSION

VALCO

VENETIAN BLIND / DRAPERY / PHOTOFRAME SECTIONS

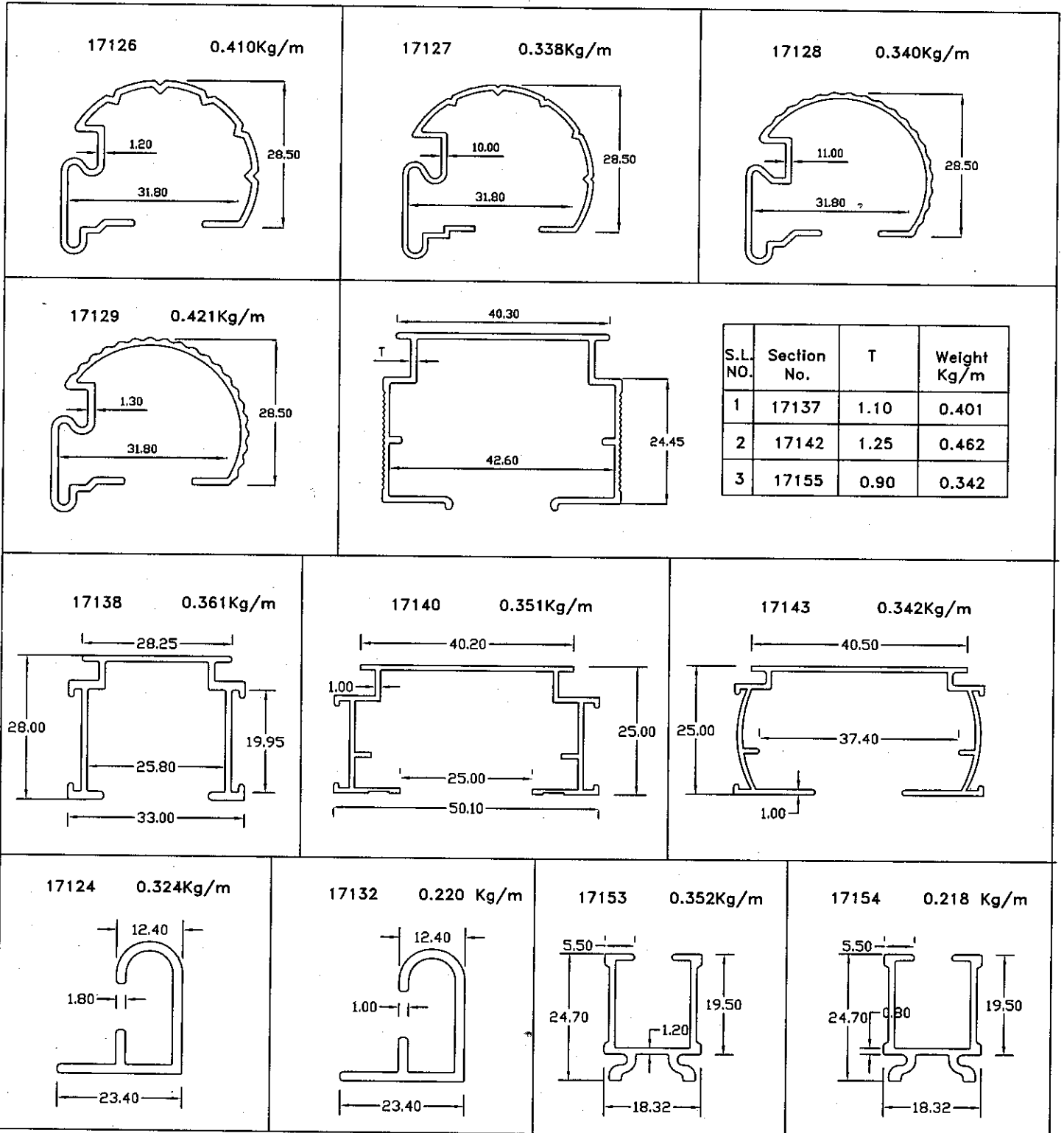

EXTRUSION

VALCO

VENETIAN BLIND / DRAPERY / PHOTOFRAME SECTIONS

17190 0.175Kg/m

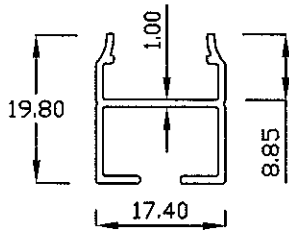

17191 0.251Kg/m

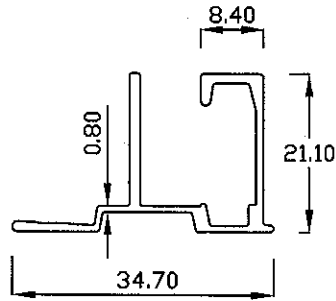

17141 40.45 0.340Kg/m

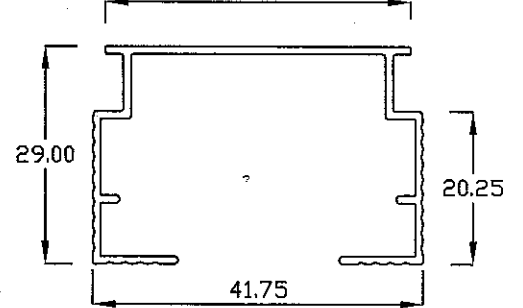

17547 0.245Kg/m

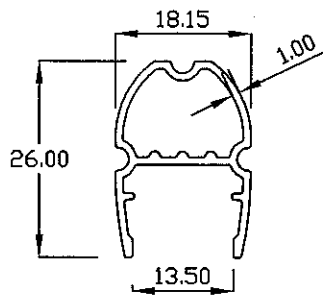

17548 0.324Kg/m

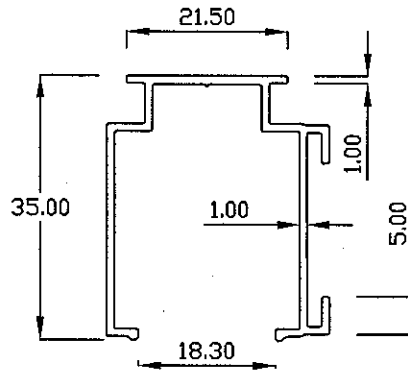

17557 0.330Kg/m

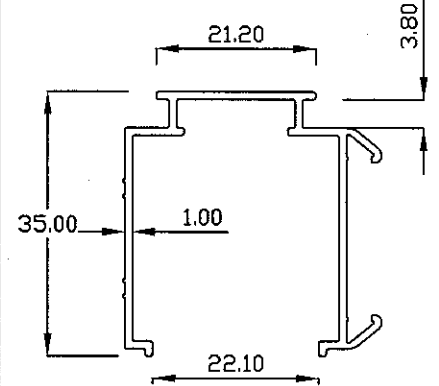

17769 0.042 Kg/m

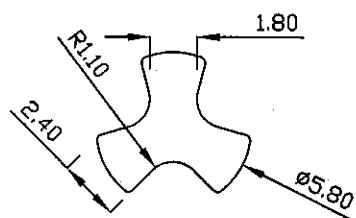

17851 0.216 Kg/m

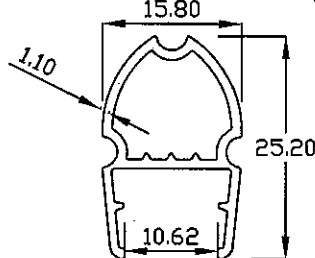

17973 0.172Kg/m

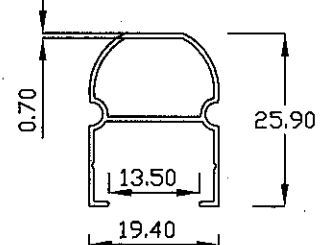

17799 0.394 Kg/m

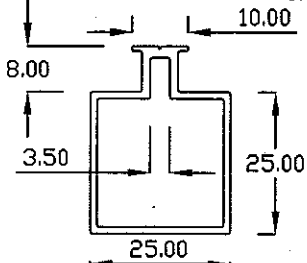

17925 0.230 Kg/m

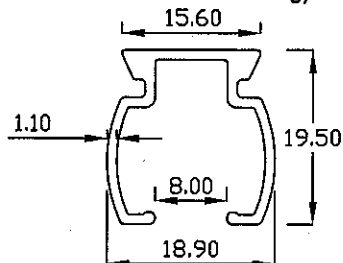

17974 0.150Kg/m

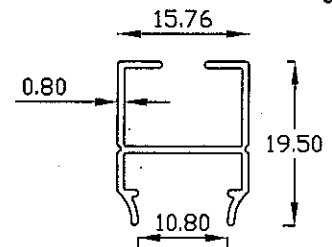

EXTRUSION

VALCO

VENETIAN BLIND / DRAPERY / PHOTOFRAME SECTIONS

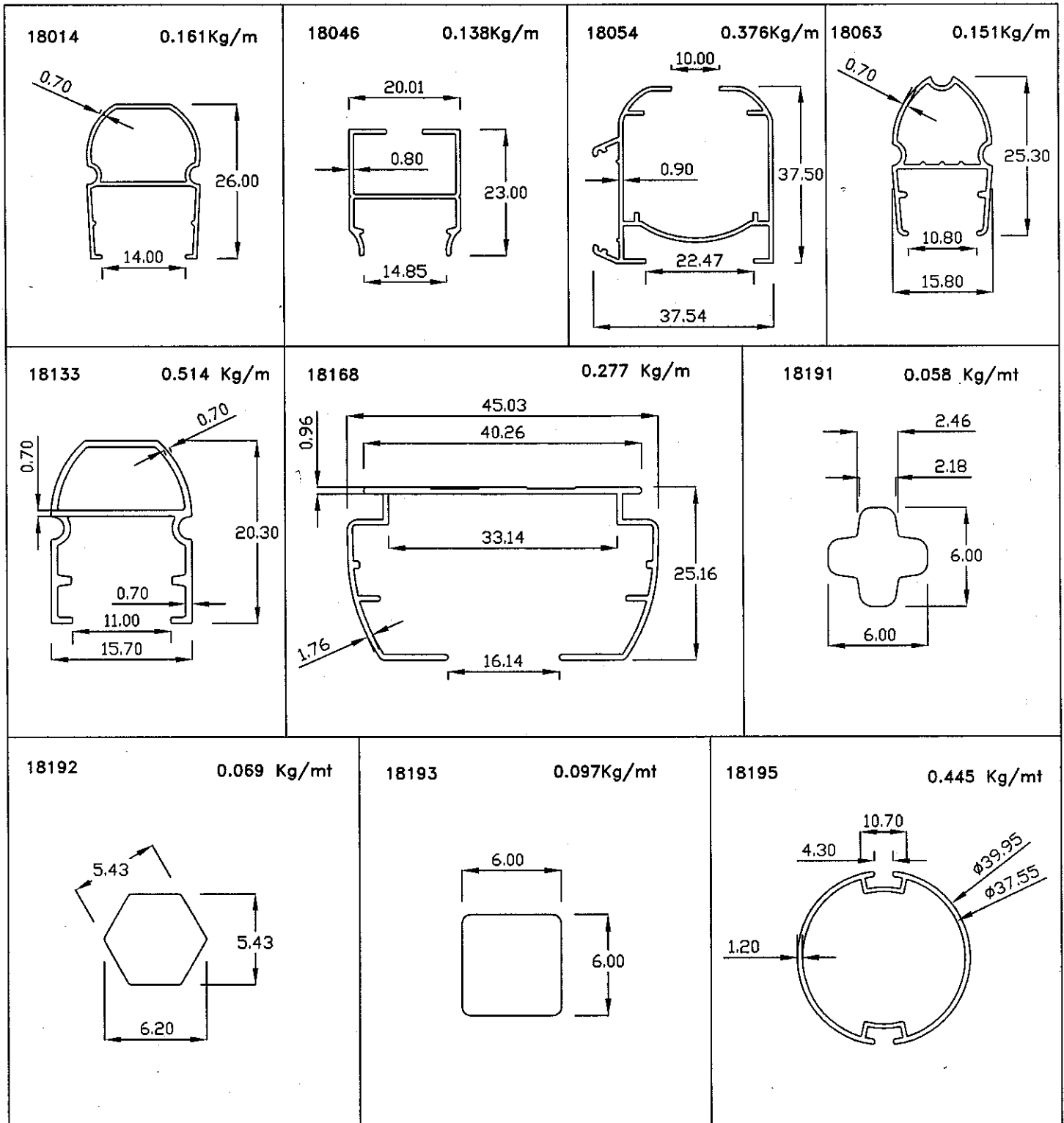

EXTRUSION

VALCO

VENETIAN BLIND / DRAPERY / PHOTOFRAME SECTIONS

<p>18196 0.255Kg/mt</p>	<p>18197 0.409 Kg/m</p>	<p>18198 0.365 Kg/m</p>
<p>18224 0.110 Kg/mt</p>	<p>18225 0.228 Kg/mt</p>	<p>18227 0.400 Kg/m</p>
<p>17743 0.160 Kg/m</p>	<p>18299 0.678 Kg/m</p>	<p>18321 0.338 Kg/m</p>

EXTRUSION

VALCO

ASSEMBLY

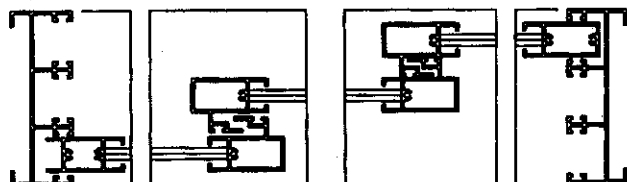
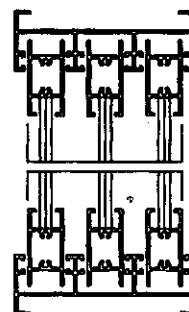
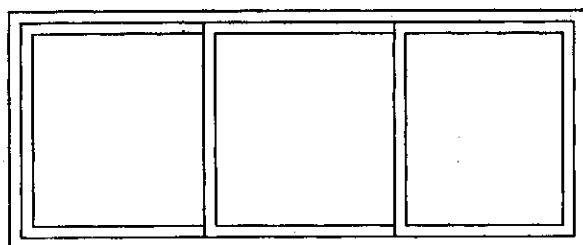

SLIDING WINDOW

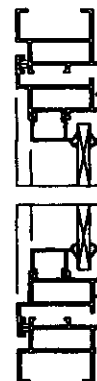
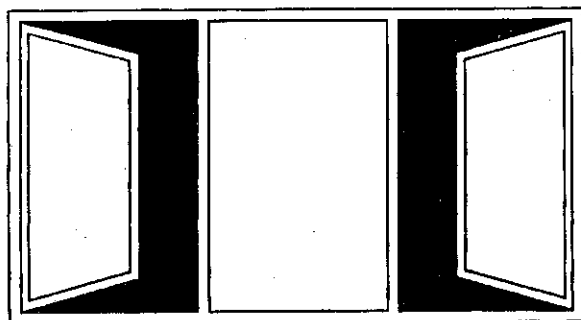

CASEMENT WINDOW